

## GENERAL DESCRIPTION

The MOBO® series 9158 is a one-piece connector used to connect two PCBs within mobile phones, pagers, PDAs, security, handheld scanners, etc. in a cost-effective manner.

A standard range is available with 16, 20, 24 and 28 contacts to suit stack heights of 1.90mm to 3.30mm. Other contact variants are also available up to 5.10mm, in custom housings. The SOLO STACKER can allow a spacing tolerance of up to  $\pm 0.30$ mm and still provide reliable connections between the PCBs, even if they are not parallel.

SOLO STACKER is designed for PCB surface mounting and is supplied in tape and reel packaging. Gold plated pads on the mating PCB or suitable flex circuits provide connection between the boards.

Whatever your requirements this SOLO STACKER can also be customized to suit your applications.

## APPLICATIONS

Suitable applications include:

- Mobile Phones
- PDA
- Medical
- PMR
- Industrial
- Security
- Handheld Scanner

## KEY FEATURES AND BENEFITS

Single piece Connector – no mating half connector required to connect two boards together which means:

- Reduced assembly time.
- Only one part to purchase and stock.
- Due to the unique contact design, the mating device does not have to be parallel.
- Extremely robust when subjected to shock and vibration.
- Cost effective.
- Helps reduce tolerance accumulation within system.



## DRAWINGS AND DIMENSIONS

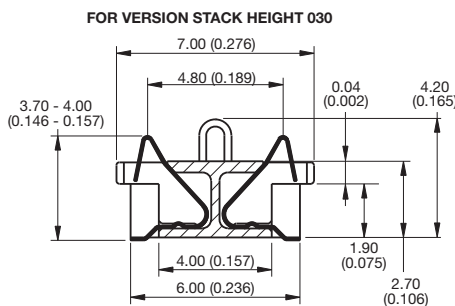
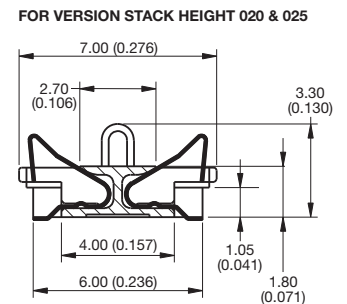
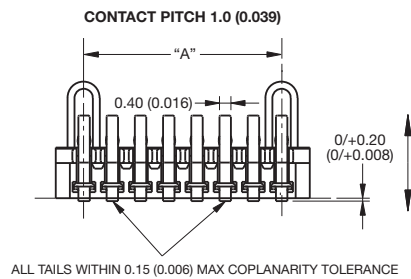
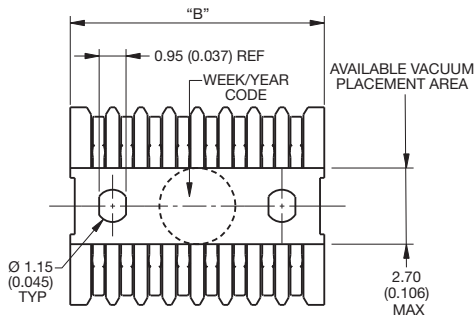

Number of Positions	Part Number	A	B
16	00-9158-016-XXX-XXX	7	9.00
20	00-9158-020-XXX-XXX	9	11.00
24	00-9158-024-XXX-XXX	11	13.00
28	00-9158-028-XXX-XXX	13	15.00

A = Number of contact pitches at 1mm  
B = Connector Length

## SMT PCB Footprint

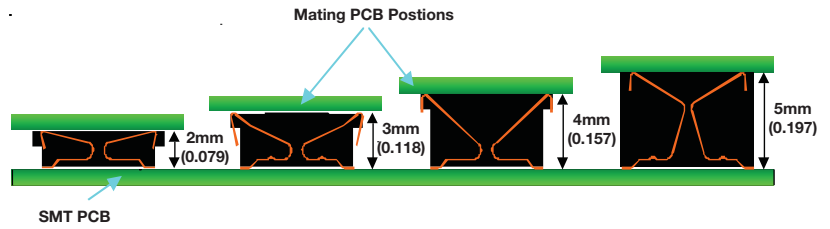
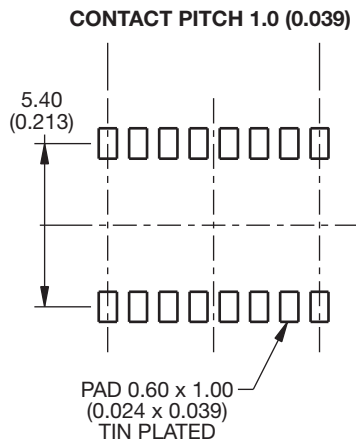

Mating Height	Standard Positions					Special Positions				
	16	20	24	28	32	4	18	30	34	40
2mm	X	X	X	X	X				X	
3mm	X	X	X	X	X					
4mm						X	X			X
5mm								X		

Other sizes available on request.

## Mating PCB Footprint for version stack height 020 & 030

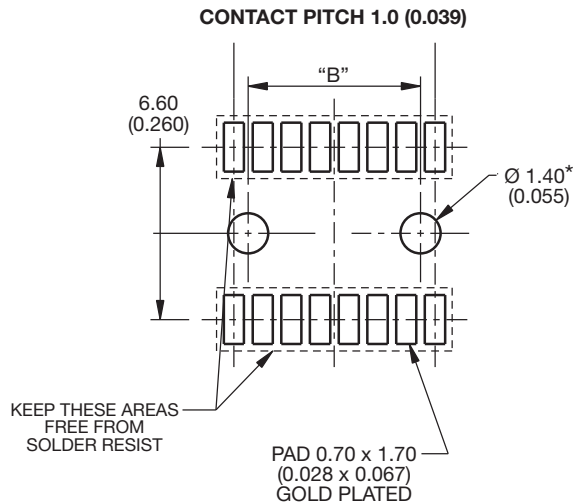

## Mating PCB Footprint for version stack height 025

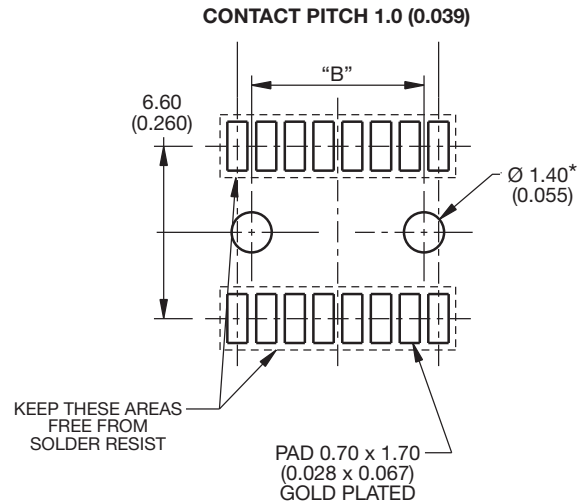

\* Used for Boss versions only.

B	Dim
16	6.00 (0.236)
20	8.00 (0.315)
24	10.00 (0.394)
28	12.00 (0.472)

## HOW TO ORDER

**00**  
Prefix  
00 = Standard  
58 = Special

**9158**  
Series

**XXX**  
No of Ways  
16 = 016  
20 = 020  
24 = 024  
28 = 028

**XXX**  
Stack Height  
020 = 1.9mm to 2.1mm  
025 = 2.1mm to 2.7mm  
030 = 2.8mm to 3.3mm

**06**  
Plating Variation  
06 = Selective Gold  
0.25µm  
Gold Plated  
Contact Nose,  
Pure Tin Tail

**X**  
PCB Location Bosses  
1 = With PCB Location Bosses  
2 = Without PCB Location Bosses